

# Casolux Machine light

Machine light system

SAMSOE

GB

IP67



Power  
3 w

Efficiency  
83 Lm/w

Lifetime  
40.000 Hours  
(70% Lumen maintenance)

Input  
10-30 VDC

Material  
Aluminum

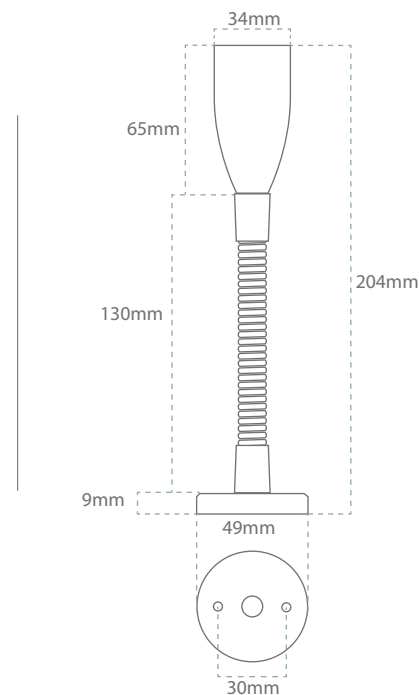

Product code	Lumen output	Beam	Power	CCT	CRI	LED brand
SAMSOE AL BL FLEX 4K 130MM	250 lm	40°	3 w	4000 K	> 85	CREE
SAMSOE AL BL FLEX 3K 130MM	250 lm	40°	3 w	3000 K	> 85	CREE

## Feature

- Powerful lights for industrial machine lighting.
- IP67 design with integral thermal management for long life.
- High precision machining ensures perfect mechanical fit for long life.
- Hard anodized aluminum ensures a corrosion free product in damp environment.
- Working temperature: -18 - +50 °C
- 1 meter Lapp Olflex cable.

## Material

- Hard anodized aluminum
- Tempered glass
- Flex in brass is covered with Black Silicon

## Benefit

- High reliability
- Maintenance free

## Application

- Machine light