

Casolux Machine light

Machine light system

ROEMOE SQUARE

GB

IP65



Power
16 w

Efficiency
100 Lm/w

Lifetime
50.000 Hours
(70% Lumen maintenance)

Input
24 VDC
220VAC

Material
Aluminum

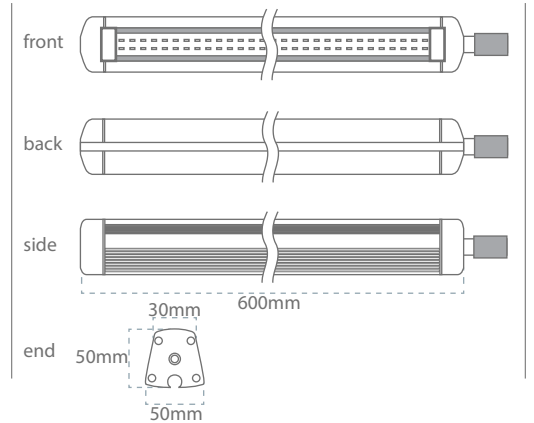

Product code	Lumen output	Beam	Power	CCT
RØMØ SQUARE 600MM 16W 220V	1640 lm	120°	16 w	4000
RØMØ SQUARE 600MM 16W 24V	1640 lm	120°	16 w	4000

Feature

- Explosion proof projector for industrial machine light.
- IP65 design with integral thermal management for long life.
- High precision machining ensures perfect mechanical fit for long life.
- Hard anodized aluminum ensures a corrosion free product in damp environment.
- Working temperature: -40 - +50 °C

Material

- Hard anodized aluminum
- Tempered glass

Benefit

- High reliability
- Maintenance free

Application

- Machine light