

# Casolux Machine light

Machine light system

ALS - Short

GB

IP65



Power  
9,5 w

Efficiency  
75 Lm/w

Lifetime  
**50.000 Hours**  
(70% Lumen maintenance)

Input  
**24 VDC**  
**220VAC**

Material  
**Aluminum**

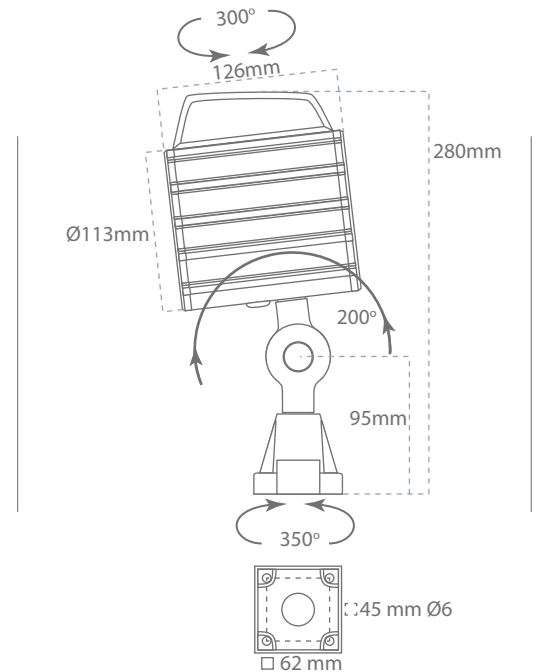

Product code	Lumen output	Beam	Power	CCT	CRI
ALS SHORT 9,5W 24V	715 lm	60°	9,5 w	4000	> 70
ALS SHORT 9,5W 230V	715 lm	60°	9,5 w	4000	> 70

## Feature

- Powerful lights for industrial machine lighting.
- IP65 design with integral thermal management for long life.
- High precision machining ensures perfect mechanical fit for long life.
- Hard anodized aluminum ensures a corrosion free product in damp environment.
- Central Lux: 70 cm = 1800-1900 lux
- Working temperature: -20 - +60 °C

## Material

- Hard anodized aluminum
- Glass

## Benefit

- High reliability
- Maintenance free

## Application

- Machine light